

extremis[®] Catalogue



EXTREMIS

Tools for togetherness



Gargantua 12
Eat & drink



Pantagruel 18
Eat & drink



Abachus 26
Eat & drink



Walrus 96
Lounge



Kosmos 104
Lounge



Sol+Luna 112
Lounge



Anker 30
Eat & drink



Extempore 36
Eat & drink



Hopper 42
Eat & drink



Inumbra 122
Shadow



Inumbria 128
Shadow



Hopper shade 132
Shadow



Pontsūn 54
Eat & drink



Marina 60
Eat & drink

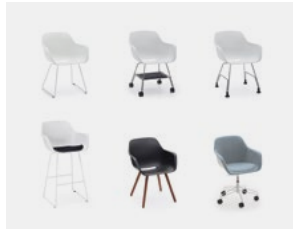

Captain's chair 68
Eat & drink



Kosmos parasol 136
Shadow



Sticks 140
Mood



Qrater 146
Mood



Picnik 76
Eat & drink



Arthur 82
Eat & drink



Virus 88
Eat & drink



Woodstock 150
Mood



Icecube 154
Mood



Romeo & Juliet 158
Mood

**This is not
furniture.**

**These are Tools
For Togetherness.**



Everything started back in 1994, when Dirk Wynants, son of a cabinet maker, decided to build his own piece of garden furniture for his young little family. He wanted his children to sit at the same eye-height as adults, so he came up with the height-adjustable benches. This was to enable better communication.

'There's so little time to spend together with all family members, so we better spend it well', he stated, and this became Extremis' mantra: let's make furniture that you can actually use, furniture that serves better conversation, furniture that makes life easier. Let's make 'Tools For Togetherness'.

In 2017 the brand Extremis combines over 20 collections of innovative outdoor and indoor products. In fact, our tools are built to be used outside. They are weather-resistant. That doesn't mean they can't be placed in an interior space. For example, many offices use our tools for togetherness for their desks, lunch areas and break-out.



At a time when communication is ruled by mails, mobile phones and social media, we believe that we need to provide solutions to improve real live face-to-face communication wherever we find it, as we are convinced that good quality communication leads to better understanding and a healthy state of mind.

Mohow zeh!

Extremis is the latin translation for a dutch word called "buitengewoon". The literal meaning of "buitengewoon" is "out of the ordinary". We make innovative new stuff, but it is ordinary at the same time: Our tools don't need to shout: 'look at me!' They have to be simple, modest and honest. We enjoy and preach the pleasure-loving Burgundian lifestyle ourselves, but for us the love of pleasure means enjoying quality, not quantity. People sometimes take a different attitude to buying furniture, which we think is a shame, because it's a waste of resources.

Westhoek, 'West Corner', is where Extremis (and most of its employees) was born and raised. This is the most rural part of Belgium, where people use words like 'Mohow zeh' to express wonder while the rest of the Belgians haven't got a clue what they are trying to say.

In 2015 all the transformations on our company premises were completed. The place really needed extensive renovation work, with Extremis applying the same methods and ethics as the ones we use to develop our products, with a focus on ecology and efficiency.



**Not the biggest company,
not the most beautiful chair,
not the longest table.**

We will probably never receive an award for the biggest outdoor company, but we have been awarded over 50 times for our designs and design management. Which all goes to show the originality of Extremis' designs and the innovative spirit we demand of all of our products and team members, year after year.

To name just a few of the awards we have received: Red Dot Design Awards, FX Design Awards, DME Awards, iF Design Awards, German Design Awards, Henri Van De Velde Labels, Good Design Awards, Green Good Design Award, and so on.



**“Don’t make anything,
unless it is both
necessary and useful”**



**“And if it is, don’t
hesitate to make
it beautiful”**

Shakers quote

Our main concern is to solve problems, not just to produce beautiful objects. And if a problem has already been solved, we need to add value at some point, otherwise, it has no reason to exist. For example, Walrus has an everlasting hide, and it stores warm and cosy blankets inside the backrests. So there are no ugly covers that ruin your terrace view. Bringing comfort outside has never been so easy!





Gargantua

DESIGN BY DIRK WYNANTS

According to an American study, parents and children currently only spend an average of 15 minutes together per day. To improve the quality of this togetherness, Dirk Wynants wanted to create a table where children could comfortably sit at the same height as the adults. This was to enable better communication.



Gargantua



↓
Drôme / France.



↑
Balegem / Belgium.

←
'Comptoir Sucrier' by
Verdickt & Verdickt architects
Antwerp / Belgium.

Eat & drink



←
Soho business park
Tokyo / Japan.

→
Dutch embassy
Rome / Italy.



Gargantua

The Gargantua table offers superior functionality thanks to its adjustable benches that can change in height depending on your social or family needs. There is a level for adults, for bigger and smaller children, or the bench can be used as an extension

of the tabletop. Provides space for 8 - 12 people. If one bench is removed, people in wheelchairs can also join the table. Gargantua is also ideal for urban spaces and project environments.

4 bench positions



Adults



Young adults



Children



XXL tabletop

Options



Backrest



Cushion



Floor fastening



Parasol ready

Cushion Finishes



White



Dark Taupe

Dimensions (cm)

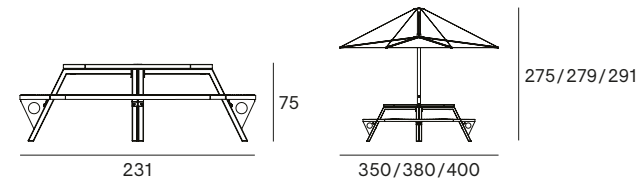



Pantagrueel

DESIGN BY DIRK WYNANTS

Pantagrueel is a chip off the old block. He's robust, elegant and sober, just like his father Gargantua, designed 20 years earlier. Together they are the most famous giants in European literature. Francois Rabelais describes them as large, strong, high-spirited, intelligent, progressive and crazy about the good things in life.



Read the full story about
the giants online!
www.extremis.be/rabelais



Eating pancakes,
a great summer
afternoon.
Poperinge / Belgium.



Sunny breakfast
Heuvelland / Belgium.





Heuvelland / Belgium.



'Blauwpoort' bed & breakfast
Heuvelland / Belgium.



When we started Extremis 20 years ago, we named our first piece Gargantua. It was based on a famous 16th-century series of novels by a French monk, Rabelais, describing the life of two giants: Gargantua - whose appetite was unstoppable -

and his son Pantagruel. The second generation, Pantagruel, is not a better version of Gargantua, he's just different. There are several material options for the frame, fixed benches and tabletop. It also features a Lazy Susan to easily pass dishes around.

Types



Pantagruel Picnic



Pantagruel table



Pantagruel high table

Options



Backrest



Cushion



Floor fastening



Parasol ready

Tabletop & Bench Finishes



Iroko



Hellwood



Hpl



White



Dark taupe

Cushion Finishes



Galva



White



Black



Black-brown



Earth

Leg Finishes



Galva



White



Black



Black-brown



Earth

Dimensions (cm)

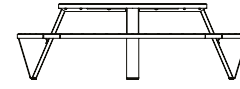

227

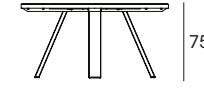

146

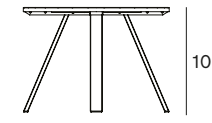

146



350/380/400

275/
279/
291



Abachus

DESIGN BY DIRK WYNANTS

Abachus is a high table with a little extra: when standing up, you can lean against one of its six arms, providing the minimal comfort you need to honour Bacchus, the god of wine, with your friends.





Heuveland / Belgium.



Thanks to its solid design and carefully selected materials, Abachus is capable of withstanding all weather conditions. Abachus combines perfectly with the 250 cm Inumbrina parasol. The optional

integrated ashtray (available in small or large) stops people from dropping their cigarette butts on the floor.

Options

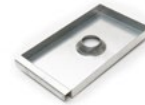

Small ashtray (2 L)



Big ashtray (6 L)



Floor fastening



Parasol ready

Tabletop Finish



Iroko

Leg Finish



Galva

Dimensions (cm)

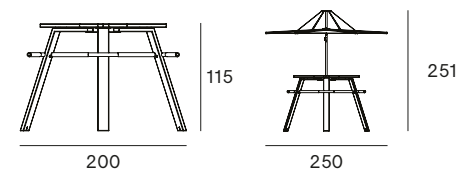



Anker

DESIGN BY DIRK WYNANTS

Sailors drop the anchor when they have reached a place where they want to stay. Sit down around Anker and touch base with your friends or family. Anchoring is about getting a grip on what is really important in life and disconnecting a bit from the daily rush at work.





Bodo restaurant
Ghent / Belgium.



Bakeries garden
Poperinge / Belgium.



→
Castle 'De Blankaart'
Diksmuide / Belgium



Anker

Ahoy sailors, let us introduce you to Anker! (anchor in Dutch), a triangular picnic table that seats six of you Popeyes comfortably. Looking at the corner face of the table, you clearly see where we got the name.

In combination with our Inumbrina parasol it's an awesome eye-catching set up! Get creative with the different colours of wood and steel to make your favourite combination that suits your way of life.

Options



Floor fastening



Parasol ready

Tabletop & Bench Finishes



Iroko



Hellwood

Leg Finishes



Galva



White



Black



Black-Brown



Earth

Dimensions (cm)

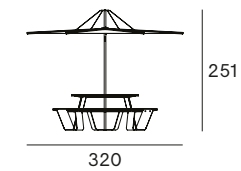
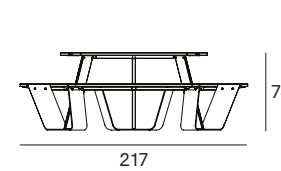



Extempore

DESIGN BY ARNOLD MERCKX

Extempore is the architectural range of tables, benches and chairs Arnold Merckx created for Extremis. As Extempore comes in a vast variety of different possibilities, any need can be satisfied within one range.

Eat & drink

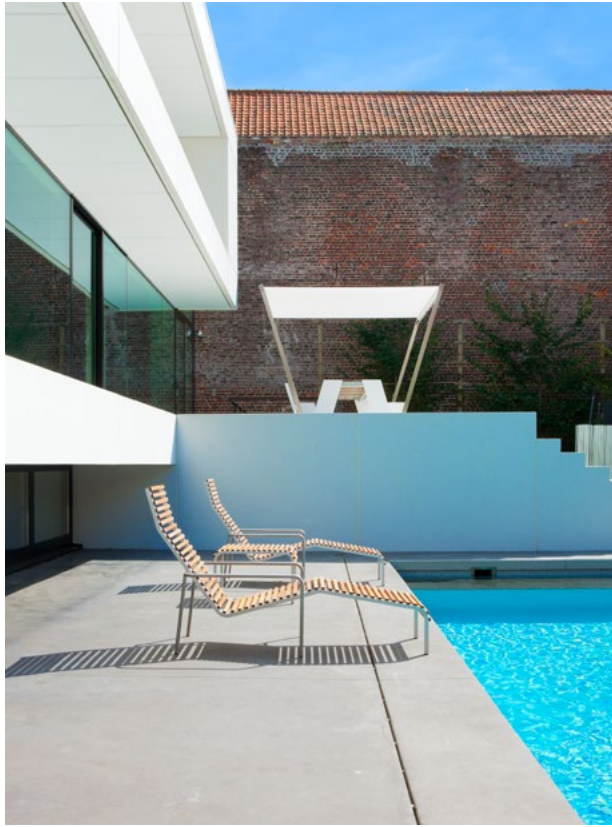

Ieper / Belgium.

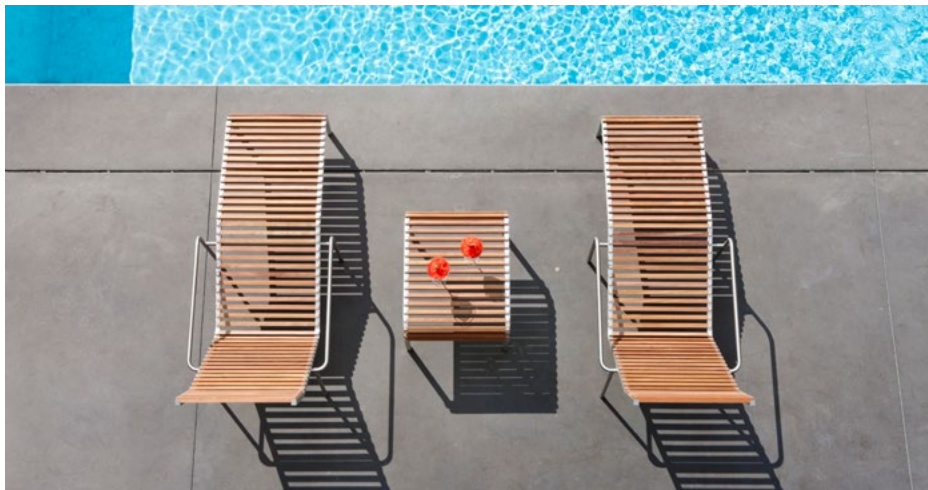

Extempore



Poperinge / Belgium.



↓
Extempore with a view
at the Opera House
Sydney / Australia.

↑
Amden / Switzerland.



Extempore is an extensive, modular outdoor furniture range offering solutions for all your day-to-day needs such as sitting, dining, lying, relaxing, reading, etc. As the Extempore range is made exclusively with top-quality materials, it can be

left outdoors all year round. The range's extensive nature is clearly exemplified by the large choice of table sizes, each with matching chairs or benches, and the foot rest, lounge chair and sun lounger that are also included in the range.

Types



Options



Cushions



Wheels for all tables

Cushion Finishes



White



Taupe

Dimensions (cm)

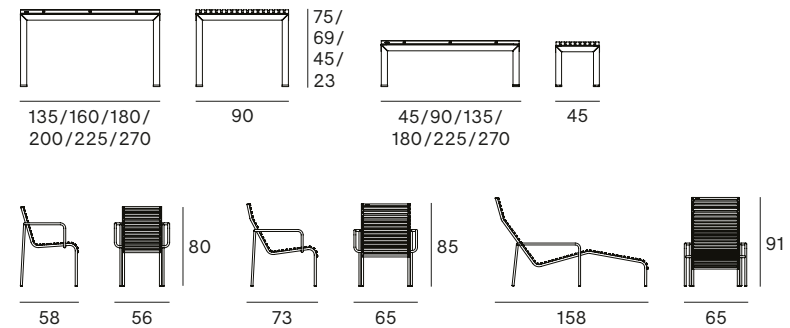



Hopper

DESIGN BY DIRK WYNANTS

At a lively beer festival, elegance is almost certainly not the main concern, but this hasn't stopped us from trying to improve access to the classic picnic table. We managed to incorporate more space at the sides to get in.



Eat & drink



Oudenburg / Belgium.



Hopper



Waasmunster / Belgium.

Eat & drink

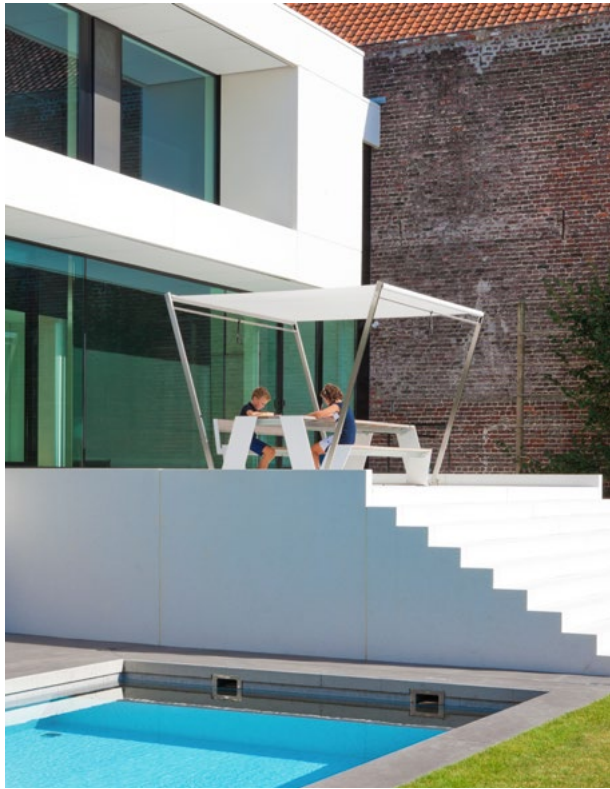

←
leper / Belgium.



→
Residence Freundorf
Vienna / Austria.

Hopper

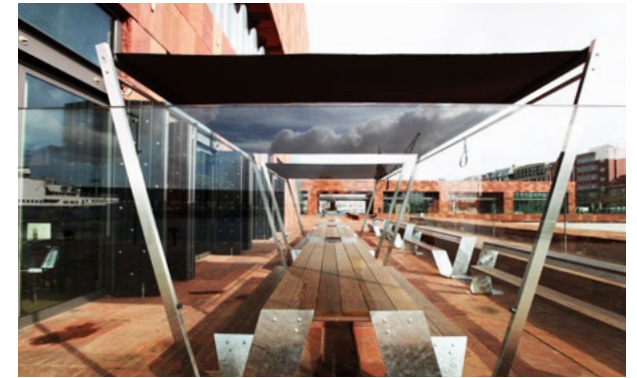

A line of galvanised
Hopper picnics and
benches with taupe
shades at MAS
Antwerp / Belgium.

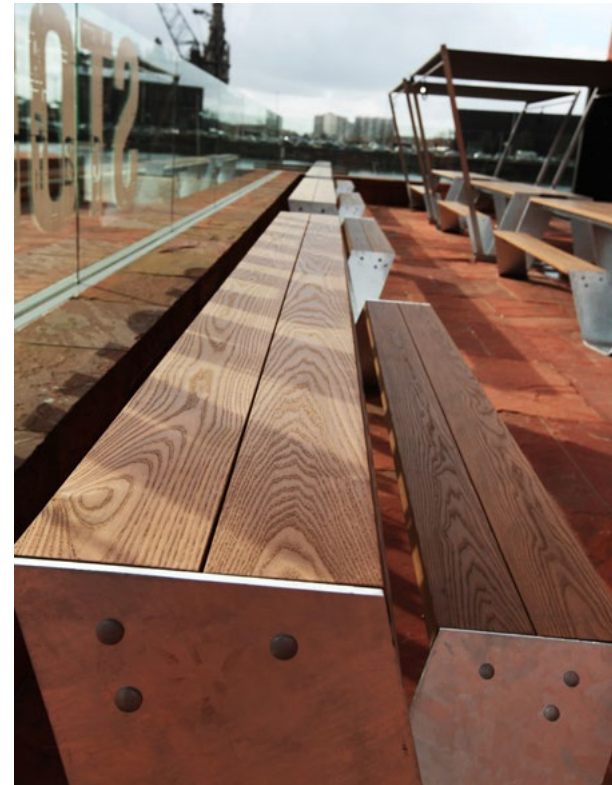

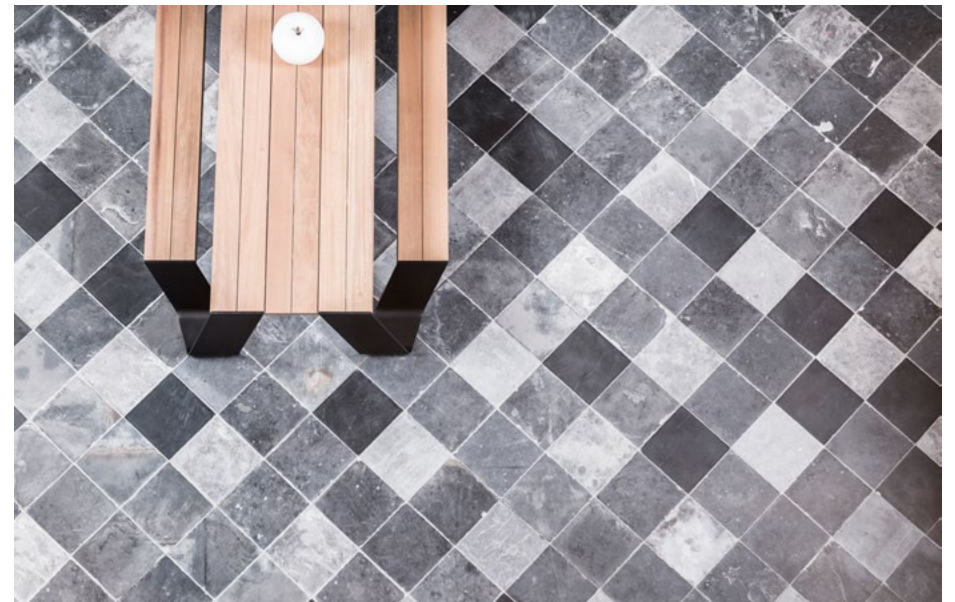

16th Century chapel by
Klaarchitectuur
Sint-Truiden / Belgium.

Eat & drink



Universiteit Leiden /
The Netherlands.



Hopper

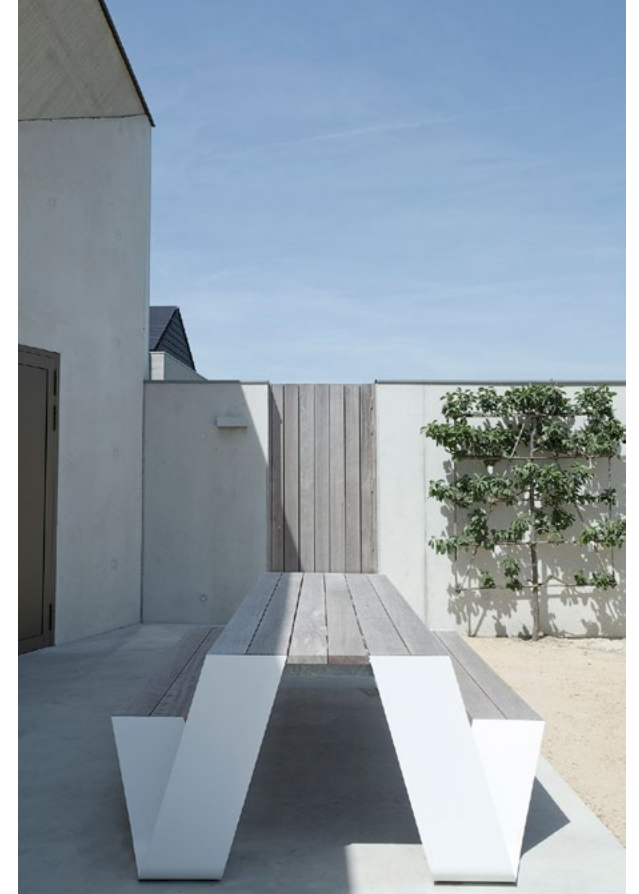

Residence by architect
Inge Clauwers
Lommel / Belgium.

Eat & drink



Hofstade / Belgium.



Hopper

Hopper clearly bears resemblance to the traditional picnic tables everybody knows, but as is typical of Extremis it offers extra comfort. The four pass-through zones make it easy to get in and out of Hopper without having to lift your leg over the bench

or disturb your table companions. Its slanted legs and tabletop edges are a clear reference to the hop poles that are so characteristic of the Westhoek region. If you turn around, you can use the tabletop as a comfortable backrest.

Types



Hopper Picnic



Hopper Combi



Hopper Table



Hopper Bench

Options



Backrest



Floor fastening



Parasol ready

Tabletop & Bench Finishes



Iroko



Hellwood

Leg Finishes



Galva



White



Black-Brown



Earth

Dimensions (cm)

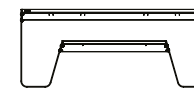

180/240/300/360

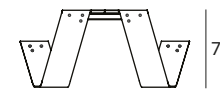

162,8

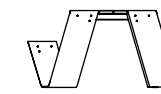

143

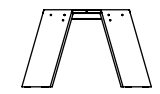

124



67,7



Pontsūn

DESIGN BY DIRK WYNANTS

This extra wide table was baptised Pontsūn, Japanese for pontoon. Indoors or outdoors, get together with a lot of friends around this large yet elegant table.





Avelgem / Belgium.



Extremis HQ
Poperinge / Belgium.



With legs inspired by the origami paper-folding technique to provide strength, and the repetition of wooden planks seen in pontoons and piers, we have called this extra wide table Ponstun, which is Japanese for pontoon. Indoors or outdoors, get

together with a big group of friends around this large yet elegant table. Experience an oriental feel with the combination of robust wood and origami-like legs, perfectly combined with Extremis' Captain's Chairs.

Types



4-6 people



6-8 people



8-10 people

Options



Captain's chair

Tabletop Finish



Hellwood

Leg Finishes



Galva



White



Black



Earth

Dimensions (cm)



255/325/395



110

74



Marina

DESIGN BY METRICA

This particular design once again shows the "Tools for Togetherness" philosophy of Extremis. The seemingly endless table is perfect for entertaining large groups of guests, friends and family.





Poperinge / Belgium.





Ardoorie / Belgium.



Eat & drink



Beveren aan de IJzer / Belgium.



How to move a 30m table???
Watch the movie!
www.extremis.be/marinapicnic

Marina

This is a picnic table in its most basic shape, made out of pultruded glass fibre profiles. This way, seemingly endless tables can be created, in one

piece. Standard, it can be up to 12m long, so that around 40 people can sit down at the table all at once. But we go way beyond.

Types



Marina Picnic



Marina Combi



Marina Table



Marina Bistro

Options



Captain's chair

Leg Finish



White

Tabletop & Bench Finishes



White

Dimensions (cm)

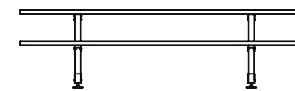

165/220/275/330/
 385/440/495/550/
 605/660/715/770/
 825/880/935/990/
 1045/1100/1155/1210

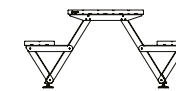

154/170

75



195/265/335/405/
 475/545/615/685/755/
 825/895/965/1035/1105/
 1175



72/87

75

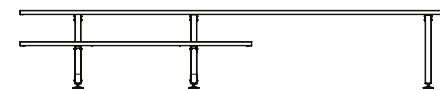

360/415/470/485/595/
 595/
 665/775/1205

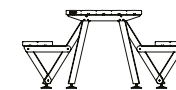

154/170

75



Captain's chair

DESIGN BY METRICA

The Captain's chair owes its name to its shape, which draws inspiration from yacht helm chairs. It's a shell offering unrivalled seating comfort, even for large or tall people.



Captain's chair



Lodge 'Blauwpoort'
Westouter / Belgium.



Home office
Poperinge / Belgium.



'Blauwpoort' Bed &
breakfast
Heuvelland / Belgium.



Eat & drink



Spa & hotel 'Wu Wei'
Kortrijk / Belgium.

Captain's chair

The Captain's chair owes its name to its shape, which draws inspiration from yacht helm chairs. It's a shell chair offering unrivalled seating comfort, even for large or tall people. Thanks to this variety of frames, the chair can be used in all kinds of

environments: public spaces, private homes, indoors, outdoors, etc. It is perfectly suited for terraces, patios, hotels, restaurants, pubs, offices, dining rooms, meeting rooms, bars and lounges, to name but a few possibilities.

Types



Sliding chair



High sliding chair



Woody's chair



High woody's chair



Paw chair



Rolling chair



Swivel chair

Options



Cushions



Upholstery



Storage net

Shell Finishes



White



Black

Frame Finishes



White



Black



Galva



Stainless steel

Dimensions (cm)

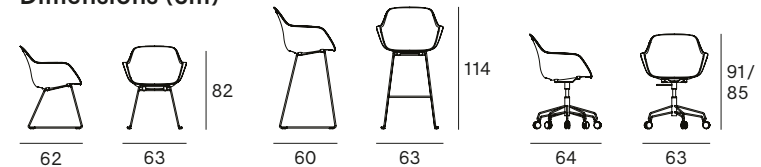



Picnik

DESIGN BY DIRK WYNANTS & XAVIER LUST

Let's celebrate Picnik in 2017!
Exactly 15 years ago, the launch of this design elevated a simple 'tête à tête' to an extremely romantic or even philosophical converse. Picnik became a real design classic, thanks to its iconic shape.



Eat & drink



↑
Standard hotel
New York / USA.

→
Tate modern
London / UK.



Picnik



Ibiza / Spain.



Vienna / Austria.

This table for two is in fact much more than just a table seating two people. Picnik was of course primarily designed as a table and bench seat combination for small outdoor spaces. But thanks to its striking looks - both solid and stylized at the

same time - Picnik is also frequently used indoors. Combining several Picnik tables in public or semi-public spaces creates an almost artistic effect. One flat aluminium sheet is transformed into a Picnik, thanks to a number of strategic incisions and folds.

Options



Floor fastening



Protective feet

Finishes



White



Black-Brown



Earth



Sky blue



Fire red

Dimensions (cm)

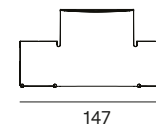

147

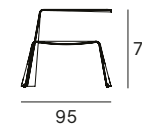

95

75



Arthur

DESIGN BY DIRK WYNANTS

How do you fit a tabletop with a diameter of up to 2.4 metres through a normal doorway? Arthur is designed like a puzzle, with eight, ten or twelve identical puzzle pieces combining to make a circular tabletop.





Villa in the jungle
Paraty / Brazil.



Architect Luc Binst
Antwerp / Belgium.

→
Arthur with Captain's
chairs at the Art Festival
Watou / Belgium.



Arthur

An equal number of arched pieces combine to create the central, supporting table leg. Not only Arthur's size, but also its design are perfect examples of the 'form follows function' principle. By making optimum use of High Pressure Laminate, you obtain

the typical shape of the legs and the tabletop. That is useful if you want to make sure that one person can carry the table anywhere they want (including up the stairs in a block of flats). Arthur comes in portable 25 kg packs.

Options



Torch

Tabletop Finish



White

Dimensions (cm)

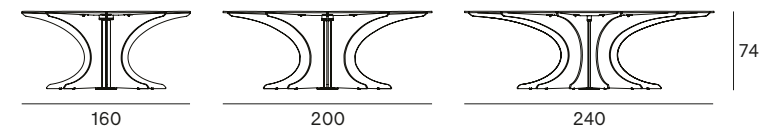



NEW

A playful, compact picnic table





Virus

DESIGN BY DIRK WYNANTS

Virus, a playful picnic table for 2/3/4/5 people, brings life and dynamism to even the most sterile areas. For every kind of gathering and every room there is an ideal Virus-table. Togetherness everywhere!

Eat & drink



Virus

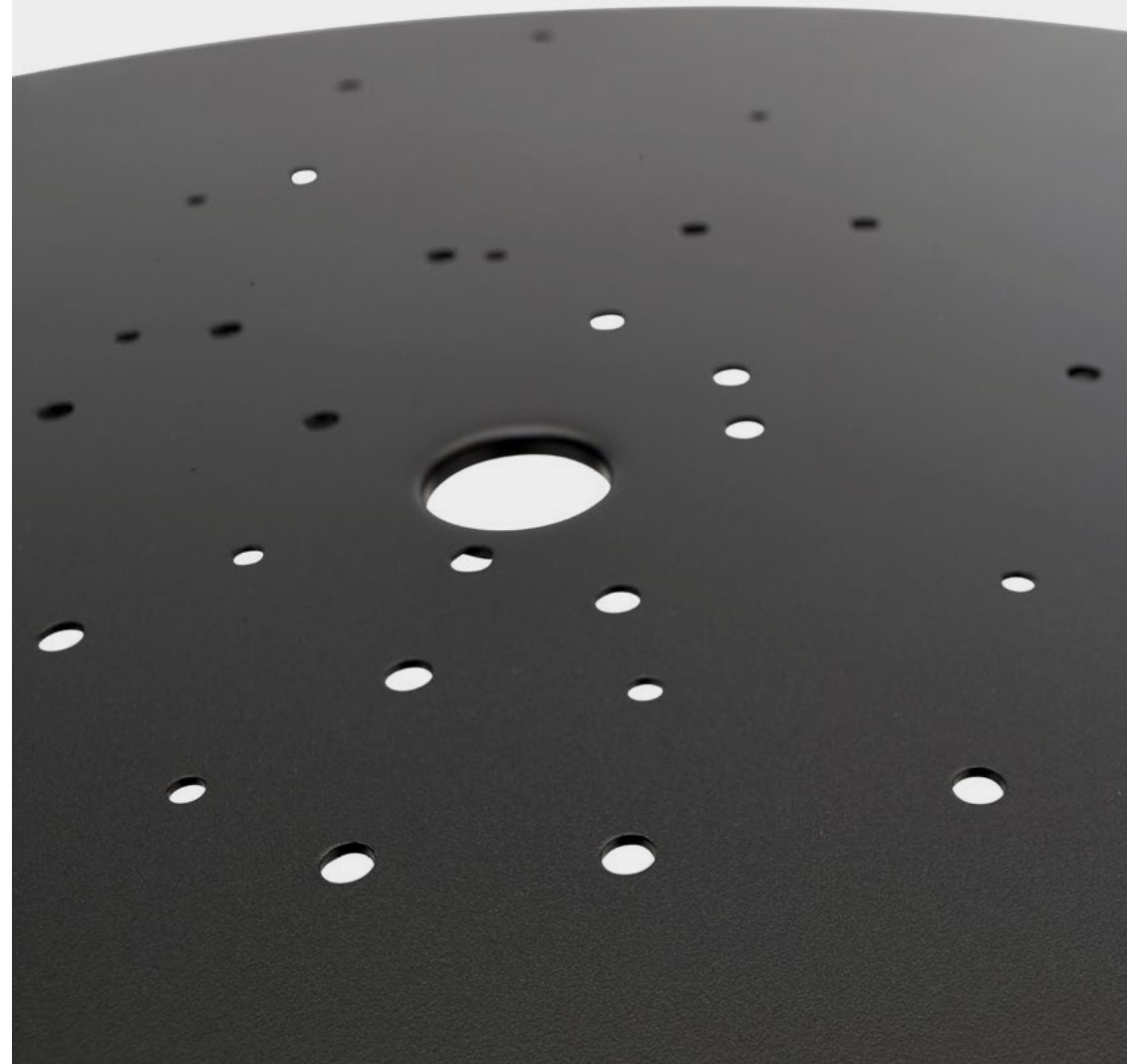

Eat & drink



Bellegem / Belgium.



Zottegem / Belgium.

Virus

Virus is a picnic table in various guises. Dirk Wynants has designed different versions based on an identical seating frame for two to five people. This is a fun way of filling a space with a mixture of small to medium-sized seating sets without losing

uniformity. What is more, the compact design responds to the trend for smaller living spaces, offering a solution that enables you to use our tools on balconies and in urban gardens. There, too, is an ideal Virus table for every gathering.

Types



2-seater



3-seater



4-seater



5-seater

Indoor Tabletop, Bench & Leg Finishes



White



Black



Earth



Silk grey



Reed green



Wine red



Sky blue

Outdoor Tabletop, Bench & Leg Finishes



White



Black



Earth



Silk grey



Reed green



Wine red



Sky blue

Dimensions (cm)

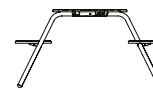

140



70

75



160



170



180

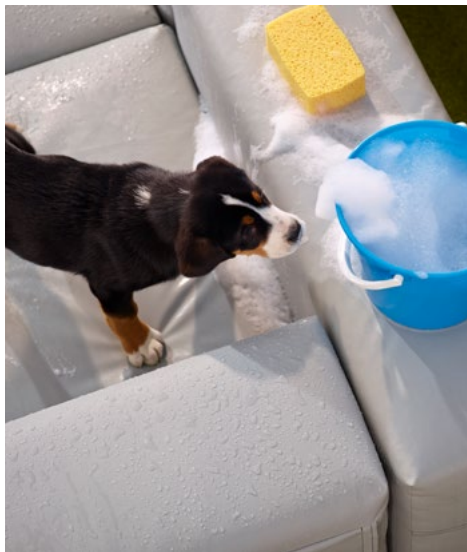

Walrus

DESIGN BY DIRK WYNANTS

Named after the impressive mammal that braves water, weather and wind with its thick, smooth hide, this design combines two different materials in order to fulfil the seemingly irreconcilable requirements of high comfort levels, aesthetics and ultimate weather resistance.





Walrus



Getting ready
Kortrijk / Belgium.



Kortrijk / Belgium.

Lounge



Spa & hotel 'Wu Wei'
Kortrijk / Belgium.



Walrus

Extremis has turned the idea of outdoor seating completely inside out, using a super-robust cover material to make a sleek, weatherproof sofa that always looks great. An ingenious storage pouch in the back of the Walrus hides a foldout blanket and a

thick cushion to provide the softness, comfort and touch that feel best in contact with your body. This softness is provided in a matter of seconds: a warm, dry and comfortable place to sit outdoors is instantly available. Yes, in all seasons!

Types



Club chair



Corner seat



Middle seat



Footstool

Options



Blankets & cushions



Side tables



Coffee tables



Anthracite coated frame

Tarpaulin Finishes



White



Light grey



Dark grey



Iroko



Hellwood

Tabletop Finishes

Cushion Finishes



White



Dark taupe



Charcoal chiné



Frosty chiné



Paprika



Mimosa

Dimensions (cm)



140/170

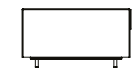

110

61

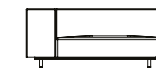

110/140

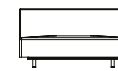

80/110



110

32



Kosmos

DESIGN BY DIRK WYNANTS

Kosmos is inspired by yachts: "When space is limited, like on a boat, we need to be more creative." Kosmos is the alternative to a combination of table, chairs, lounge chairs, sun protection, and so on. All functionalities combined in one!



Lounge



An entire day in the Kosmos
Ruddervoorde / Belgium.



Lounge



Kosmos

Sun & water fun in
'Earth' powder-coated
Kosmos 3-seaters
Westouter / Belgium.



Lounge



Rooftop terrace
Kortrijk / Belgium.



Kosmos

Kosmos has a round shape for more intense conversations and cosier cuddling at night. At its lowest position, the optional adjustable table offers a completely flat surface, transforming Kosmos into

a giant lounger. This multi-purpose set takes you right through the day - from breakfast to sunbathing - without stuffing your roof terrace full of furniture.

Types



8-seater low



8-seater high

Options



Height adjustable table



Freestanding table



Pouf



Parasol ready

Frame Finishes



White



Earth

Cushion Finishes



White



Black



Cream



Pearl

Dimensions (cm)

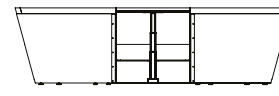

260/280

73/108

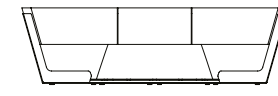

251/271

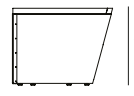

95/108

73/108



NEW

The sunbed sofa





Sol+Luna

DESIGN BY DIRK WYNANTS

Sunbathe during the day, lounge with friends by night. Take it easy in our Sol+Luna sunbed, which transforms into a comfortable sofa at sunset. The optional sun shade changes into a full moon every night...



Private residence
Zottegem / Belgium.





Sol+Luna

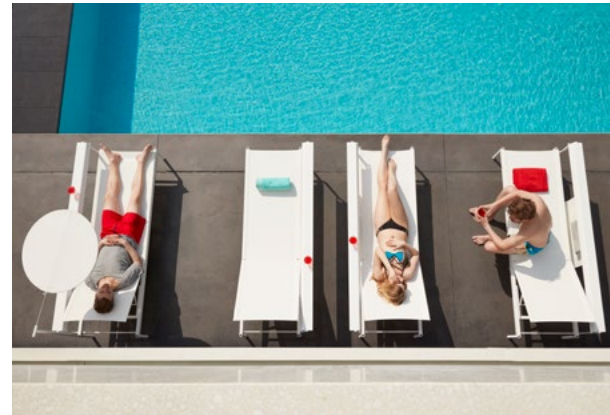

The perfect city
centre patio
leper / Belgium.

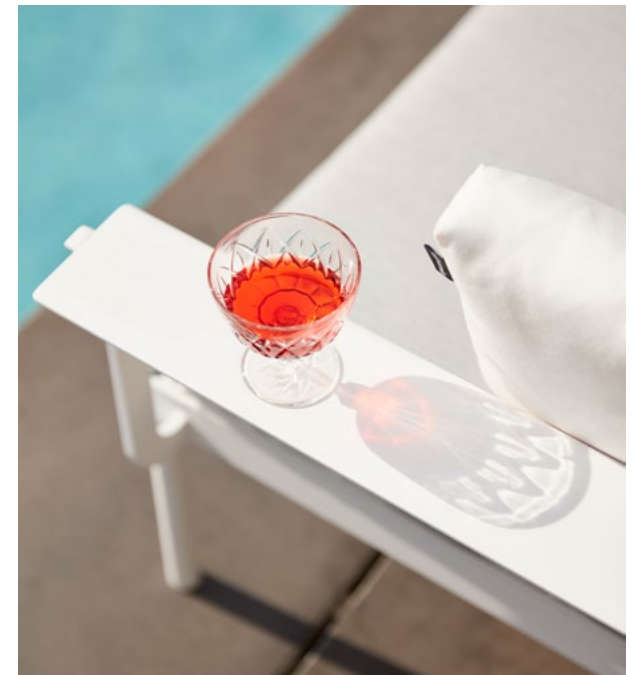

Lounge



Lennik / Belgium.



Sol+Luna

Sol+Luna is a two in one piece: furniture that has a function by day and by night. The perfect way to make optimal use of your patio. The Sol+Luna range is in two versions. The southern version, Australis, is clean and architectural, whereas the northern

version, Borealis, has a somewhat more organic look. Depending on the surroundings where the furniture will be placed, you can choose the finish that suits you best.

Types



Australis



Borealis

Parasols



With Led



Without Led

Options



Recliner & comfort cushions



Storage net



Locker



Tapa table

Frame & Batyline Finishes



White



Black

Table Finishes



White



Black

Cushion Finishes



White



Dark taupe



Grey chiné



Grey chiné



Carbon

Dimensions (cm)

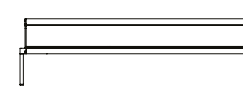

210



77

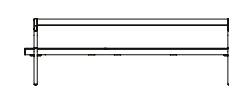

200



86



Inumbra

DESIGN BY DIRK WYNANTS

The classic parasol has become so familiar that hardly anyone would stop to consider how it could be redesigned. Inumbra is the result of improving every single aspect a parasol has.



Shadow



Au Comptoir Vénitien
Rennes /France.



Landeskrlinikum
St.Pölten /Austria.

Shadow



'T Weuwhof
Poperinge /Belgium.

Inumbra

Inumbra is unique because of his pure aesthetics. Easy to open and close: the parasol opens and closes with a separate handle. All technical parts that open and close the screen are above the Inumbra's UV resistant fabric, which means they are not visible when seated under the parasol. Inumbra

has been submitted to wind-tunnel testing at the Von Karman Institute. Although the parasol can withstand wind speeds of up to 8 on the Beaufort scale, it is off course advisable to close it sooner (from wind speed 6 as a rule of thumb).

Options



Floor fastening



Concrete base



Concrete wheel base



Cover

Parasol Colour



White



Black



Taupe

Dimensions (cm)

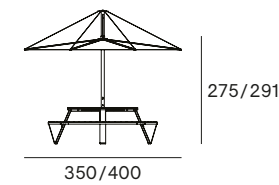
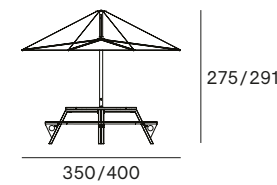
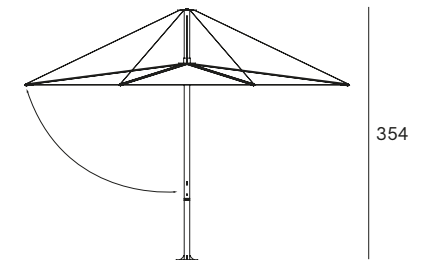
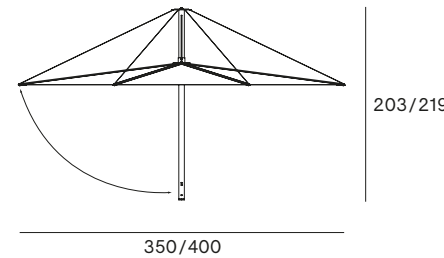



↑
Hospital terrace
AZ Jan Palfijn
Ghent / Belgium.



→
Poperinge / Belgium.



Inumbrina

DESIGN BY DIRK WYNANTS

Inumbrina is a lighter version of Inumbra and the difference between these two parasols lies in how they are opened. All the technical parts that open and close the screen are above the UV-resistant fabric.



Shadow



↓
Diksmuide /Belgium.

↑
Kortrijk /Belgium.



Inumbrina

The major difference between Inumbra and Inumbrina lies in how they are operated. When converting to a thinner and lighter central pole, the challenge was to replace the handle and

spindle system. Our technical team came up with an ingenious pulley and rope system. Opening and closing the parasol with a rope turns out to be really easy, and even faster!

Options



Floor fastening



Concrete base



Concrete base wheel



Low/high
table base



Cover

Parasol Colour



White



Black



White

Tabletop & base Colour



White



Black

Dimensions (cm)

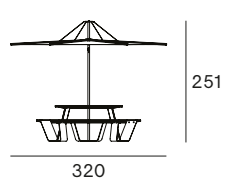
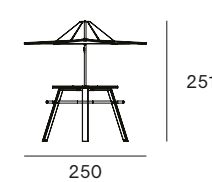
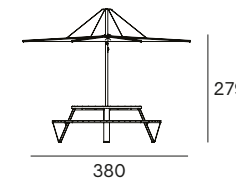
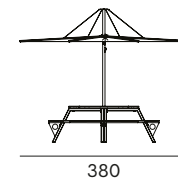
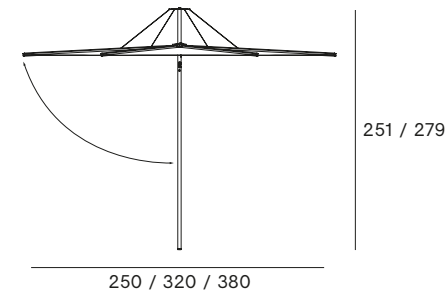



Hopper Shade

DESIGN BY DIRK WYNANTS

Extremis' headquarters are based in the only hops region in Belgium, so the hop gardens that dominate the landscape inspired us to design Hopper shade. The slanted poles of the Hopper canopy withstand a lot of stress, just like the poles of a hops garden do.

Shadow



Restaurant Va & Vient
Kortrijk / Belgium.



Hotel rooftop
Fukoaka / Japan.



Hopper Shade

Whether open or closed, Hopper Shade perfectly follows the lines of the Hopper table. It opens and closes without any effort, thanks to a spring mechanism inside. And above all, it does not take up extra space next to the table. The goal was to create enough shade for

everyone in a simple and aesthetically pleasing way. Dirk Wynants found the solution in the Hopper canopy. The cloth only has to be closed during strong winds, and then it rolls itself up. The materials used – stainless steel and hi-tech polyester fabric – are highly durable.

Options



Floor fastening



Concrete base



Assembly under
Hopper Picnic



Assembly to
Hopper legs



Cover

Parasol Colour



White



Grey taupe

Dimensions (cm)

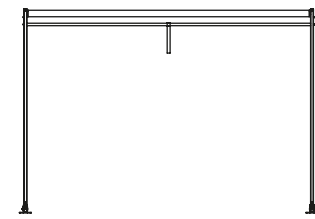

240 / 300 / 360

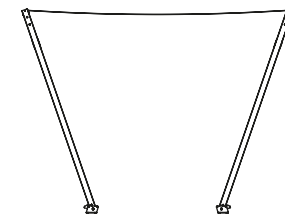

268



Kosmos Parasol

DESIGN BY DIRK WYNANTS

We wanted to devise an umbrella that did not stand in the way when it was closed. The original (and patented) innovation is that it simply opens and closes horizontally like a fan... Or a bird's wings. Design by nature!

Shadow



↑
Lake Lucerne / Switzerland.

↓
Fukoaka / Japan.



Kosmos Parasol

Kosmos parasol is an ingenious design that opens horizontally like a fan, offering excellent wind resistance (wind force 6 on the Beaufort scale). It hangs low enough to provide lots of shade, and is perfect for placing next to the Kosmos table and seat

combination or any other furniture. Hidden magnets keep the parasol open. In very windy weather, the magnets will release their grip and the parasol will close automatically.

Types



Round Parasol



Square Parasol

Options

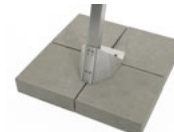

Concrete base



Floor fastening



Dimmable Led light



Cover

Parasol Colour



White



Taupe



Black

Dimensions (cm)

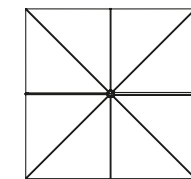
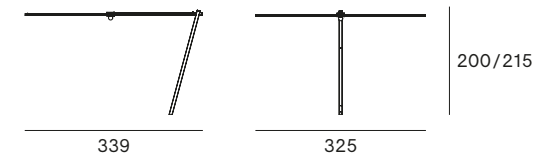
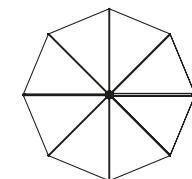
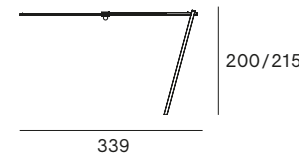

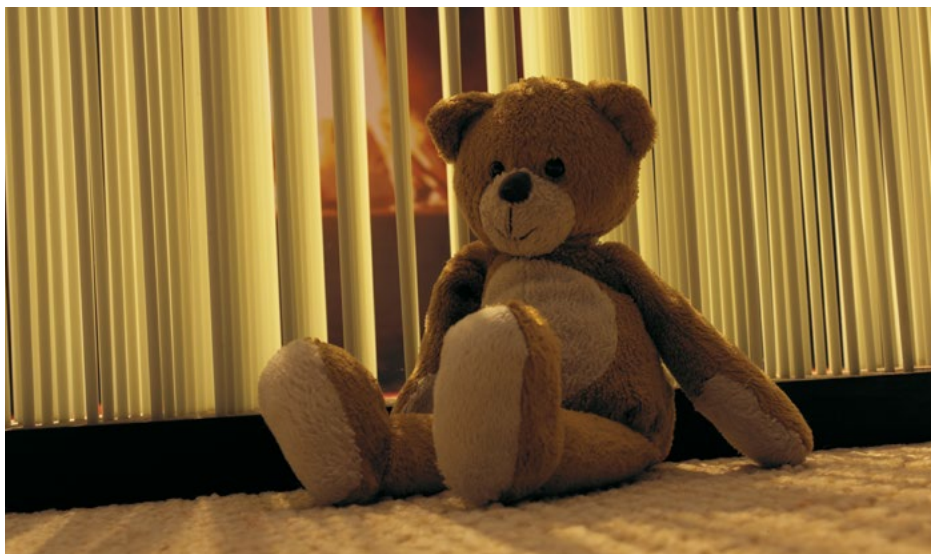

Sticks

DESIGN BY HSU-LI TEO & STEFAN KAISER

A space divider and the perfect way to create privacy wherever needed, inside or outside. Sticks divide your room or terrace optically, without losing the feeling of spaciousness.

Mood



Covent Garden Office
Brussels / Belgium.

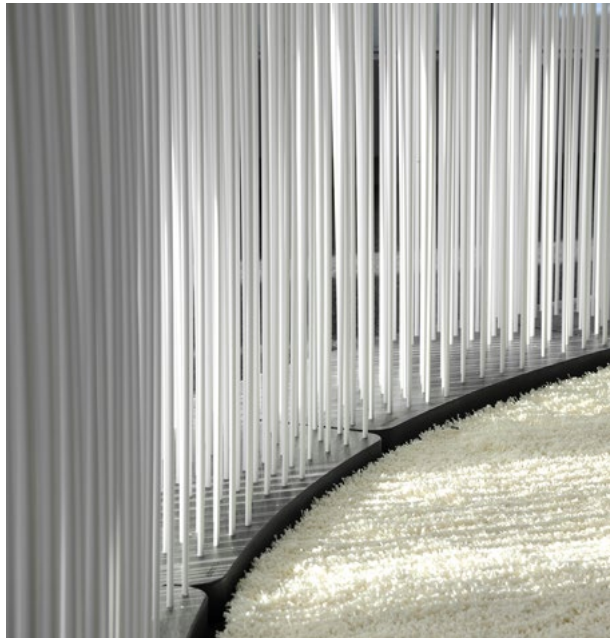

Sticks



Mandarin Oriental hotel
Miami / USA.



Ruddervoorde / Belgium.

This space divider is ideal for creating a feeling of privacy in a garden or on a balcony without losing the sense of freedom typical of open spaces. Sticks was the result of a search for a multiuse screen with outdoor applications. Use Sticks indoors to adapt the look of a room or office arrangement

entirely to your own taste. With Sticks you can create your own space over and over again. You can also choose which and how many rods you use and create various degrees of transparency, colour combinations or differences in length. Delivered with optional feet for delicate floors.

Types



Options



Cool / warm white LED

Bases Finish

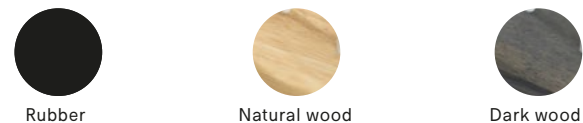

Rods Finish



Dimensions (cm)

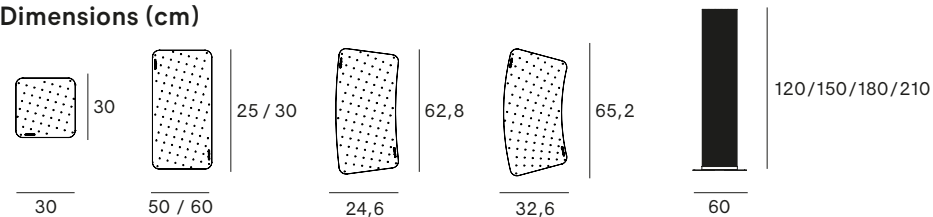



Qrater

DESIGN BY DIRK WYNANTS

Modern living has almost become a bit too comfortable. The higher our standards of living and luxury, the more we long for the basics, the simple things in life. Let us present to you: the Television Of The Jungle!

→
Meulebeke / Belgium.



←
WATT building
Ghent / Belgium.

Qrater is a campfire dish made of weathering steel, a type of steel that can be used in the garden as well as in open spaces. It only rusts on the surface, leaving the rest of the material intact. This means Qrater can stay outdoors all year round. A small hole

in the middle allows drainage of rain water or ashes into a smaller dish integrated into the galvanised steel pedestal. This pedestal also prevents heat damage to the surface below Qrater, as there is no direct contact between the dish and the ground.

Options



Grill



Skewer

Material



Weathering steel

Dimensions

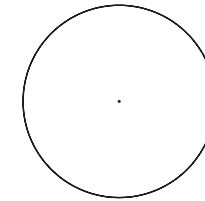

960 / 1460



Woodstock

DESIGN BY DIRK WYNANTS

Woodstock is the perfect addition to your Qrater firepit or fireplace. Frame the wood logs with the Woodstock rack and transport them easily wherever you need. The cart is also capable of supplying the beers once the Qrater is lit...



Mood



→
Woodstock and
Qrater are the perfect
combination.



←
Store your wood indoors.

Woodstock

Woodstock consists of a firewood rack and matching cart. You can fill the rack with a considerable number of logs and then transport them effortlessly to wherever you want. The rack keeps the logs stacked neatly and attractively right where you need them, perfectly combining beauty and functionality. Woodstock is not only about great

functionality. Like most other Extremis products, it also offers great environmental efficiency. As the cart is made of the leftovers from the rack, hardly anything goes to waste. Furthermore, a smart packaging design ensures a very compact transport volume. Woodstock can hold 1.18 m³ of wood if you use 30 cm logs.

Finish



Galva



Black

Dimensions (cm)

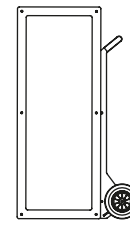

71



40

122

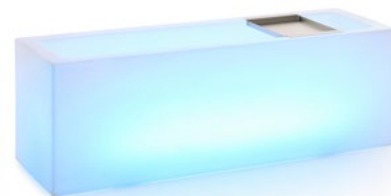
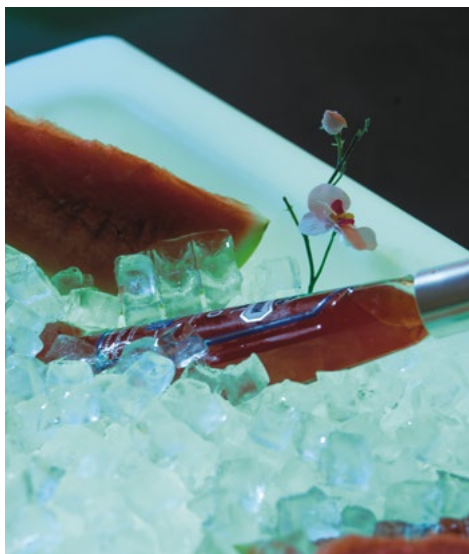

Icecube

DESIGN BY DANNY VENLET

Hosting a garden party? Icecube prevents your guests raiding the fridge or soiling the whole house. Self-service all night long! And the cool lighting effects get everyone in a party mood...

→
Ardooie / Belgium.



←
Garden of an interior
stylist
Avelgem / Belgium.

This drink cooler adds the perfect finishing touch to any party, whether indoors or outdoors. Icecube does not only chill the drinks and keep them within reach; its optional lighting unit also creates the perfect party atmosphere. Hosts don't have to wait on their guests or put up with people coming into their kitchen and raiding their fridge. And the cool

lighting effects get everyone in a party mood... Icecube does not contain any cooling elements: Its double wall acts as an insulator. To fill Icecube completely you need 25 kg of ice. Icecube is made mainly of rotationally moulded polyethylene (PE), which is 100% recyclable.

Options



Light Set

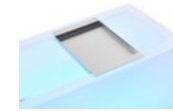

Serva Tray

Material



Polyethylene

Dimensions (cm)

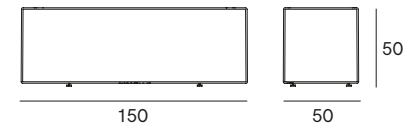



Romeo & Juliet

DESIGN BY KOEN BAEYENS, STIJN GOETHALS
& BASILE GRAUX

Romeo & Juliet adds some green to an often colourless urban or industrial setting. The bench is made of long, rectangular strips of wood. Two holes in the seat create room for large flowerpots.



Mood



↑
Romeo & Juliet in a row
Tapiola / Finland.

→
De Lovie Castle
Poperinge / Belgium.

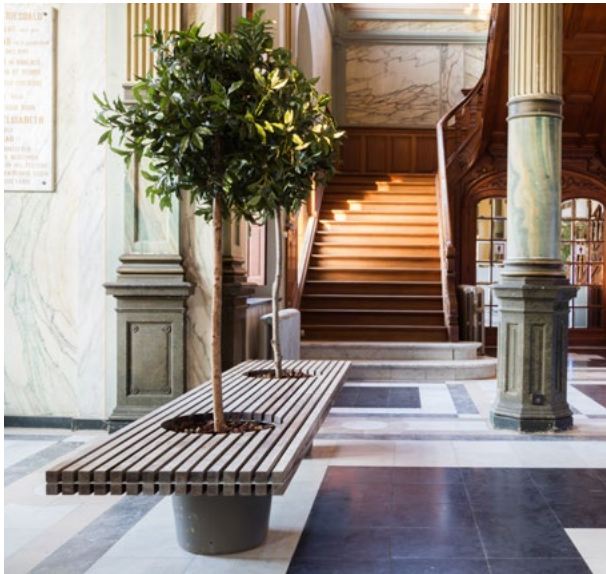

Romeo & Juliet

Romeo & Juliet offers passers-by a comfortable place to sit and relax and also adds a touch of green to an otherwise drab urban or industrial setting. Two round holes in the seat create room for large flowerpots, perfect for a small tree or a plant of your choice. Just like Romeo and Juliet, the trees are destined to be together without ever being able to

touch. The bench seems to float between the trees. Obviously, Romeo & Juliet lends itself perfectly to the contract market: when several benches are put in line, the distance between the trees remains identical, creating architectural harmony. They are of course perfectly suited to private gardens or patios as well.

Option



Connector

Seat



Jatoba FSC®

Pot



Glass fibre reinforced polyester

Structural parts



Galvanised steel

Dimensions (cm)

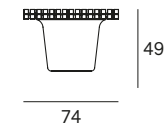
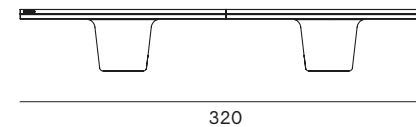

Extremis 3D planner & configurator

Plan and configure with our 3D app and find out which tool for togetherness fits best in your garden.

FREE - THE APP STORE



Download the APP here!
www.extremis.be/services

Colophon

EDITOR

Dirk Wynants Design Works
info@dwdw.be

LAY-OUT

Bram Coudijzer
Diego Froidmont
Ferre Verdonck

PUBLISHER

Extremis – Hilde Louwagie
hilde@extremis.be

EXTREMIS

Couthoflaan 20b
8972 Poperinge – BELGIUM

WWW.EXTREMIS.BE

+32 57 346020
info@extremis.be

IMAGES

Beeldcollectief
Verne
Photographil
Arne Jennard
Hilde Verbeke
Joost Demuyndck
Piet De Kersgieter
Thomas 'Switn' Sweertvaegher
Abbas Almohri
Sam Gilbert
Simone Vogel
Katsy.org^o
Thomas Libiszewski
Marc Wallican
Jordi Huisman
Mónica Penaguião
Luis Diaz Diaz
Studio PSG
Frederik Buyckx
www.klaarchitectuur.be
Caroline Dethier
Frank Pittoors

All rights reserved. Unless otherwise specified, all designs and photographs contained in this publication are copyright protected and are the property of Extremis. No part of this publication may be copied or distributed without Extremis' prior written consent. The names of the authors of photographs to which we do not hold rights are mentioned here. We have done our utmost to provide a comprehensive list of names. In the event of an alleged breach, please contact the editorial staff.

© Extremis 2017

BE THE FIRST TO KNOW

Facebook
Twitter
Linkedin
Pinterest
Instagram
Vimeo



FOR TOGETHER
HERNESHOOES